

How We Began...

Glenn Harp & Sons, Inc., was founded in 1976. Our purpose was to offer quality products at competitive prices in any quantity, with on-time delivery and impeccable customer service. We set out with these basic ideas and they have worked!

The growth Glenn Harp & Sons, Inc., has experienced over the years is due, in part, to our flexibility and responsiveness to our customers' needs. Our employees are dedicated to customer satisfaction. Our sales representatives are specialists in the field, and they want to get to know you, to understand your business, and to satisfy your needs.

We have a toll-free number to place orders, get quotes, and confirm inventory. If you have a special need, give us a try. We welcome challenges. Most importantly, we keep our commitments.

Douglas R. Harp
President

GLENN HARP & SONS, INC.

4662 North Royal Atlanta Drive
Tucker, Georgia 30084-3801

Phone: (770) 491-8127

Fax: (770) 491-8104

1-800-282-HARP (4277)

www.harpstarps.com



OPEN ACCOUNT

A prospective 'Open Account' customer must complete and sign a Credit Terms Agreement, a Credit Application, and, if applicable, a State Sales Tax Exemption Certificate. Credit is extended to accounts with good credit references and a good payment history.

TERMS

Standard terms are 2% 10, net 30. This means that a discount of 2% may be taken if we receive your check *within 10 days of invoice*, and that all invoiced amounts are due 30 days from the date of invoice.

DISCOUNT

For your convenience, the discount amount and discount due date are shown at the bottom of invoices. Discounts will not be allowed after 10 days and will be charged back to the customers. Customers who do not pay any unearned discounts will be placed on Net 30 terms. Customers who refuse to pay the unearned discounts are subject to having their accounts placed on C.O.D. status for future orders.

FINANCE CHARGES

Finance charges will be assessed against the unpaid balance of all invoices that become 31 days old and will be compounded at the rate of 1½% per month, or 18% annually. Customers who refuse to pay finance charges will be placed on C.O.D. status until the finance charges are paid. Finance charges are due at the time they are assessed.

CREDIT HOLD

Accounts reaching 60 days past due may be placed on credit hold. This will freeze any shipments or orders in house until the overdue invoices and service charges are paid in full.

**RETURNS**

Goods which are new and in their original packaging may be returned, at the customer's expense, with a pre-approved Return Authorization number. There will be a 15% restocking charge on all returns. Custom parts or merchandise that is out of its package or has been installed or used may not be returned.

PURCHASE ORDERS

We prefer that all orders be placed in writing and faxed, along with a Purchase Order number, for easier tracking. Written orders help avoid misunderstandings.

CUSTOM ORDERS

A written Purchase Order, along with a drawing, must be faxed for all custom orders. Custom ordered tarps are not returnable.

Contents

TRANSPORTATION INDUSTRY

| | | |
|--------------------------|----------------------------------|-------|
| STEEL SYSTEMS | Electric Tarping Systems | 1 |
| | Manual Tarping Systems..... | 2 |
| | Wand Arm Assemblies..... | 3 |
| | Replacement Parts..... | 4-5 |
| TARPAULINS | Dump Truck Tarps | 6-7 |
| | Quick Reference Charts | 8-9 |
| | Flatbed Tarps | 10-12 |
| | Trailer Tarps..... | 13-16 |
| | Refuse Tarps..... | 17-18 |
| | Tarp Material Descriptions | 19 |
| ACCESSORIES | | 21 |
| | REPAIRS | 22 |

NURSERY / AGRICULTURE

| | |
|--------------------------------------|----|
| TARPS & SHADE CLOTH | 23 |
|--------------------------------------|----|

INDUSTRIAL APPLICATIONS

| | |
|--------------------------------------|----|
| BLUE POLY TARPS | 24 |
| SILVER/BLACK POLY TARPS | 25 |
| INDUSTRIAL APPLICATIONS | 26 |



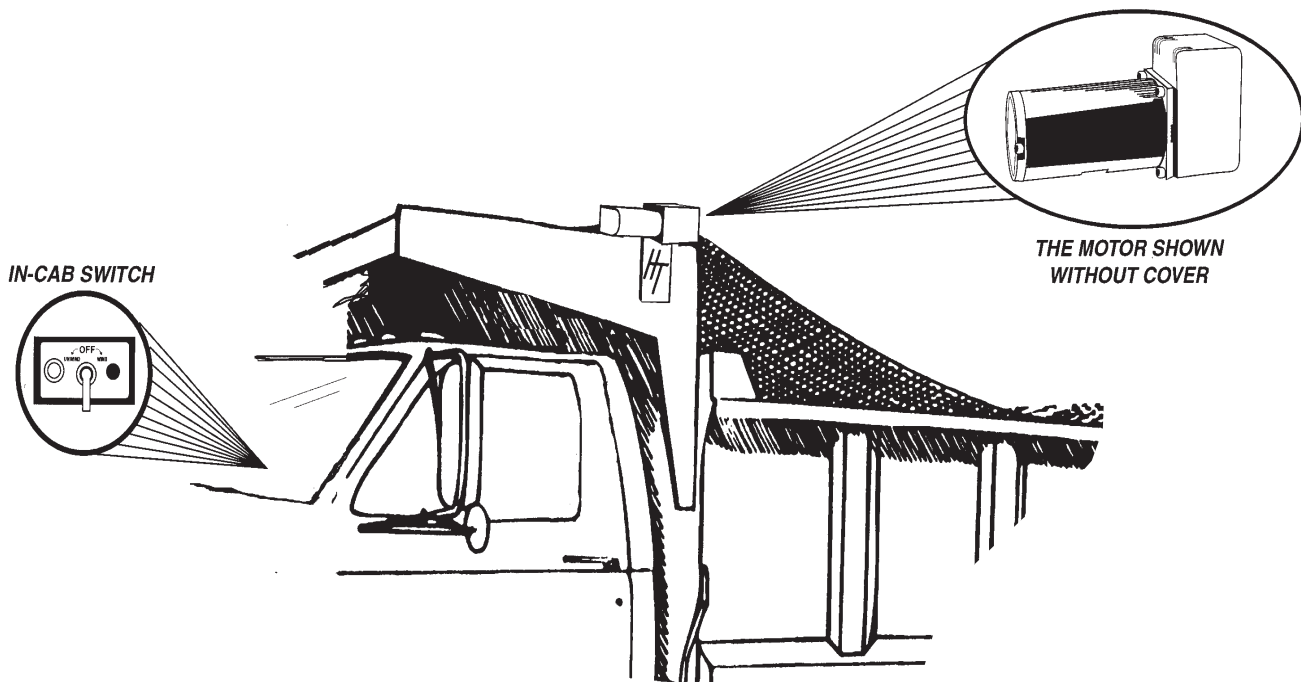

ELECTRIC TARPING SYSTEMS

- Automatic Operation
- Rolls Up Tarp In Seconds
- Inside Cab Switch
- Motor Totally Enclosed

Both systems include the ETA Bar (see page 2)

(Tarp and Wand systems sold separately.)

PART# GHS 2500HT

Recommended for bodies up to 20' long

- Heavy-duty direct drive electric motor assembly with 3/4" shaft
 - 62 RPM at output (no load)
 - Oil bathed gear box using 5 precision ball bearings
- Pre-drilled 93" ETA Bar
- Wiring kit with switch and mounting plate
- 50' of 6 gauge wire
- All attaching parts
- Complete instructions
- Ships in two boxes
 - Assembly 32 lbs
 - Motor 10 lbs

PART# GHS 3500ST

Recommended for bodies over 20' long

- Super-duty direct drive electric motor assembly with 3/4" shaft
 - Spur and helical gearing with 6 precision gears and 9 precision bearings
 - Provides 200% more power than GHS 2500HT
 - 62 RPM at output (no load)
 - Oil bathed gear box using 7 precision ball bearings
- Pre-drilled 93" ETA Bar
- Wiring kit with switch and mounting plate
- 75' of 6 gauge wire
- All attaching parts
- Complete instructions
- Ships in two boxes
 - Assembly 35 lbs
 - Motor 24 lbs

Wand Arm Assembly choices - Page 3

Replacement Parts - Page 4



E.T.A. Bar! (Easy Tarp Attaching Bar)

MANUAL TARPING SYSTEMS

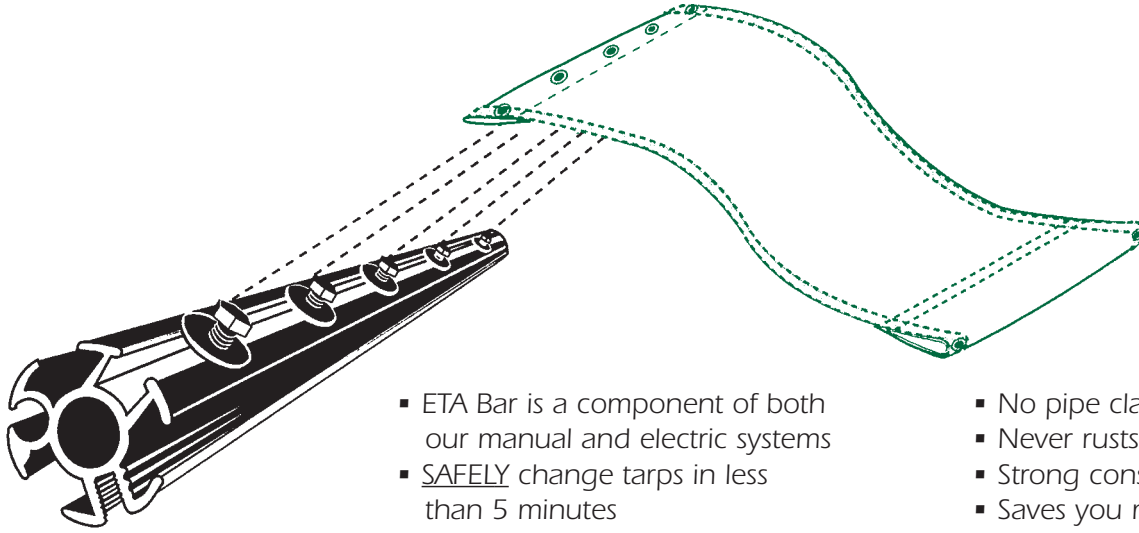

- ETA Bar is a component of both our manual and electric systems
- SAFELY change tarps in less than 5 minutes
- No need to redrill mounting holes when installing tarp
- No pipe clamps
- Never rusts - aluminum
- Strong construction
- Saves you money

Manual Wind-Up System

PART # GHS 1500/ETA

Fits most standard size dump beds – 24 lbs

- System mounts on top of cab
- Operates easily from inside cab or cab step
- All crank systems are secured by a hardened sprocket and dog (ratchet system) which prohibits back spin and possible injury
- Pull cable releases the ratchet to cover complete load



Courtesy of Superior Truck & Equipment

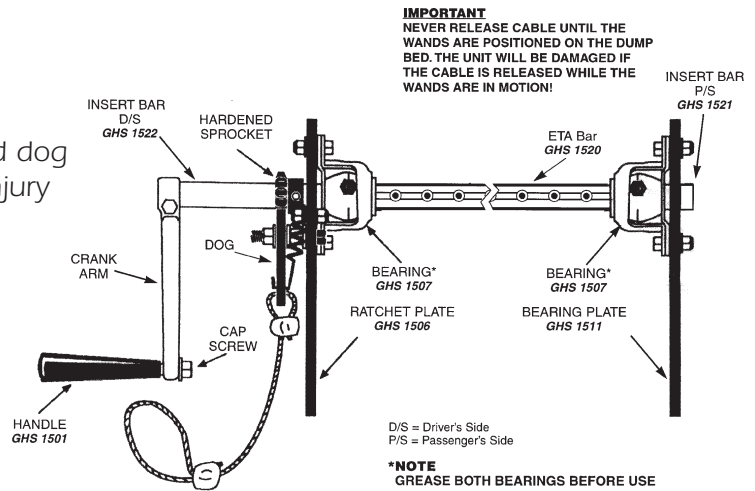

Wand Arm Assembly choices - Page 3
 Replacement Parts - Page 5

Steel Systems

WAND ARM ASSEMBLIES

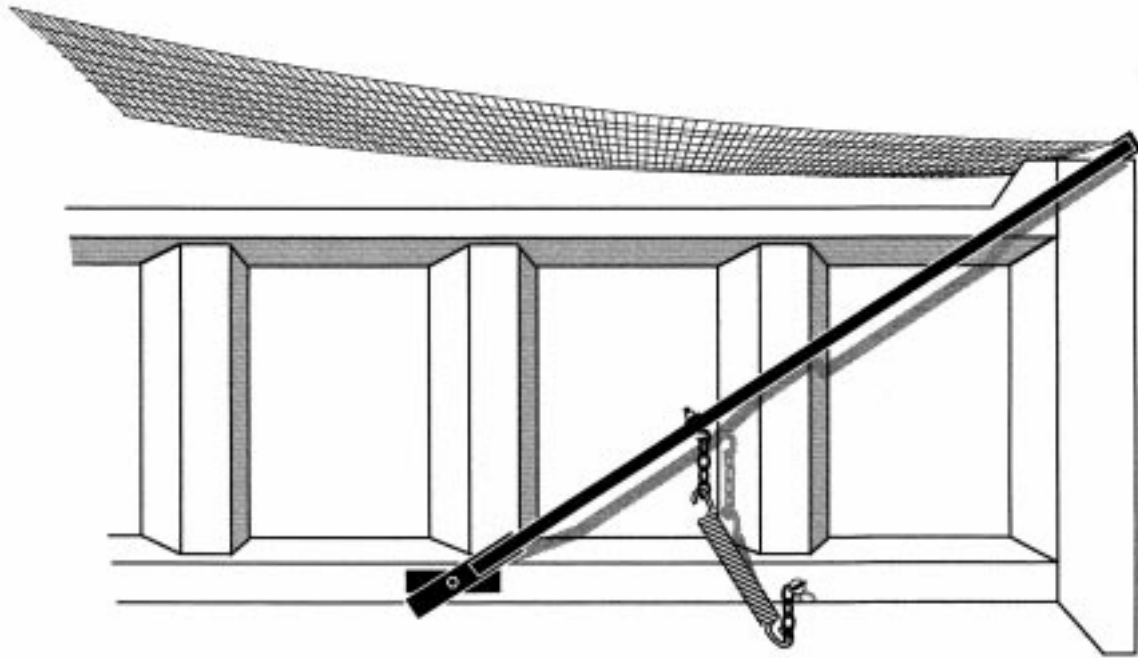

- Square steel tubing for strength
- Telescoping arms are completely adjustable to fit your truck
- All wands can be either bolted or welded to truck bed
- Wand springs are adjustable
- Top 90 degree elbow is rolled and not welded for additional strength
- Primed black for rust protection

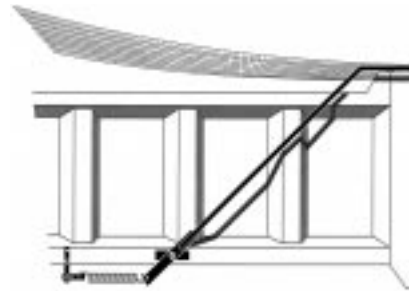

| PART # | Weight | Side Mount Assembly |
|---------------|---------------|------------------------------|
| GHS 5050 | 43 lbs | Fits 8' - 12' dump bed |
| GHS 5050-A | 45 lbs | As above with 60° angle arms |
| GHS 5060 | 56 lbs | Fits 12' - 18' dump bed |
| GHS 5060-A | 60 lbs | As above with 60° angle arms |
| GHS 5070 | 65 lbs | Fits 18' - 24' dump bed |
| GHS 5070-A | 67 lbs | As above with 60° angle arms |

| PART # | Weight | LOWER Mount Assembly |
|---------------|---------------|------------------------------|
| GHS 5050LS | 44 lbs | Fits 8' - 12' dump bed |
| GHS 5050LS-A | 48 lbs | As above with 60° angle arms |
| GHS 5060LS | 53 lbs | Fits 12' - 18' dump bed |
| GHS 5060LS-A | 57 lbs | As above with 60° angle arms |

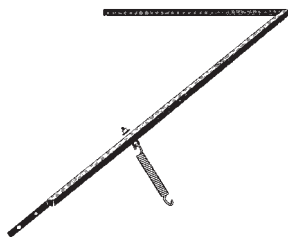

SIDE MOUNT

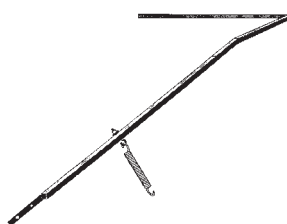

SIDE MOUNT 60°

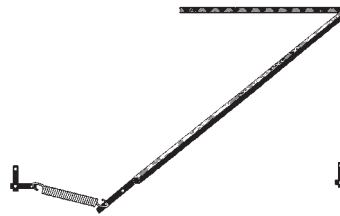

LOWER MOUNT

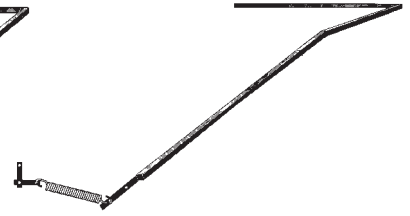

LOWER MOUNT 60°

Motors

| PART NO. | UNIT DESCRIPTION |
|----------|--|
| GHS 2501 | High Torque Gear Motor - Direct Drive with 3/4" shaft (with cover) |
| GHS 3501 | Super Duty Gear Motor - Direct Drive with 3/4" shaft (with cover) |
| GHS 2509 | Protective Cover for High Torque Gear Motor |



GHS 2501

Electrical Kit

| PART NO. | UNIT DESCRIPTION |
|----------|---|
| GHS 2505 | Wiring Kit w/ Switch and Mounting Plate |

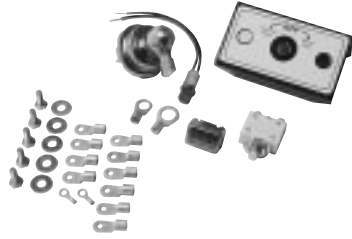

GHS 3501



GHS 2509

Switch

| PART NO. | UNIT DESCRIPTION |
|----------|---|
| GHS 2506 | Heavy Duty Rotary Switch |
| GHS 2514 | Mounting Bracket (for Switch, Circuit Breaker, and Indicator Light) |

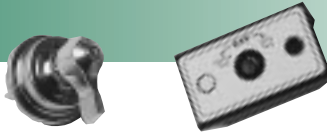

GHS 2507

Electrical Wire

| PART NO. | UNIT DESCRIPTION |
|----------|---|
| GHS 2507 | 6 ga. Dual Conductor 255 strand wire - sold by the foot |



Miscellaneous

| PART NO. | UNIT DESCRIPTION |
|----------|---|
| GHS 2502 | DS Mounting Plate |
| GHS 2503 | PS Bearing Plate |
| GHS 2508 | 18" Insert Bar |
| GHS 2510 | 3/4" Bearing with threaded grease fitting, flanges and mounting bolts |
| GHS 2511 | 93" Aluminum ETA Bar |
| GHS 2513 | DS Insert Bar |

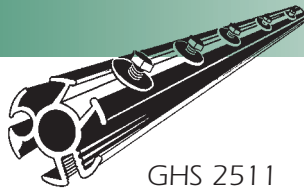

GHS 2511



GHS 2510

PART # REPLACEMENT SPRINGS FOR WAND ASSEMBLIES

Pre-galvanized wire for rust protection, made to specifications for our wand systems.

| | |
|----------|--|
| GHS 1513 | Short Spring 11 1/4" (*Maximum extension 13 1/2") For 5050LS, 5050LS-A, 5060LS & 5060LS-A |
| GHS 1514 | Medium Spring 17 3/4" (*Maximum extension 29"-31") For 5050 & 5050-A |
| GHS 1515 | Long Spring 27 3/4" (*Maximum extension 47"-50") For 5060, 5060-A, 5070 & 5070-A |

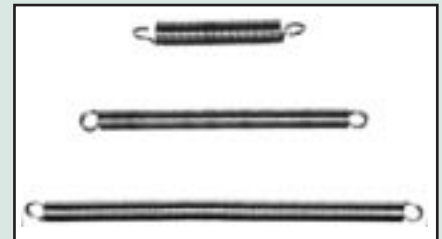

*Recommended maximum length of safe extension before possible distortion of spring or loop end. Continued extension of spring to maximum length will reduce the life of the spring.

Steel Systems

REPLACEMENT PARTS FOR MANUAL SYSTEMS

REPLACEMENT PARTS LIST GHS 1500 / ETA Manual System

| PART # | ITEM |
|----------|---------------------|
| GHS 1501 | Black Handle |
| GHS 1502 | Crank Arm & Handle |
| GHS 1503 | Hardened Sprocket |
| GHS 1504 | Spring (Ratchet) |
| GHS 1505 | Pull Cable & Sleeve |
| GHS 1506 | Ratchet Plate |
| GHS 1507 | Bearing |
| GHS 1511 | Bearing Plate |
| GHS 1512 | Dog (for sprocket) |
| GHS 1520 | ETA Bar 93" |
| GHS 1521 | 18" P/S Insert Bar |
| GHS 1522 | D/S Insert Bar |

GHS 1502

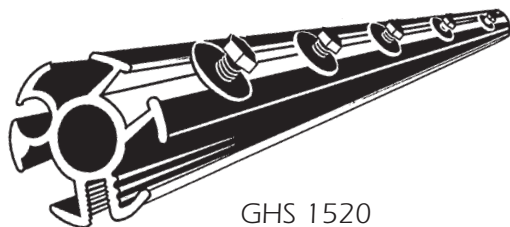

GHS 1520



GHS 1507

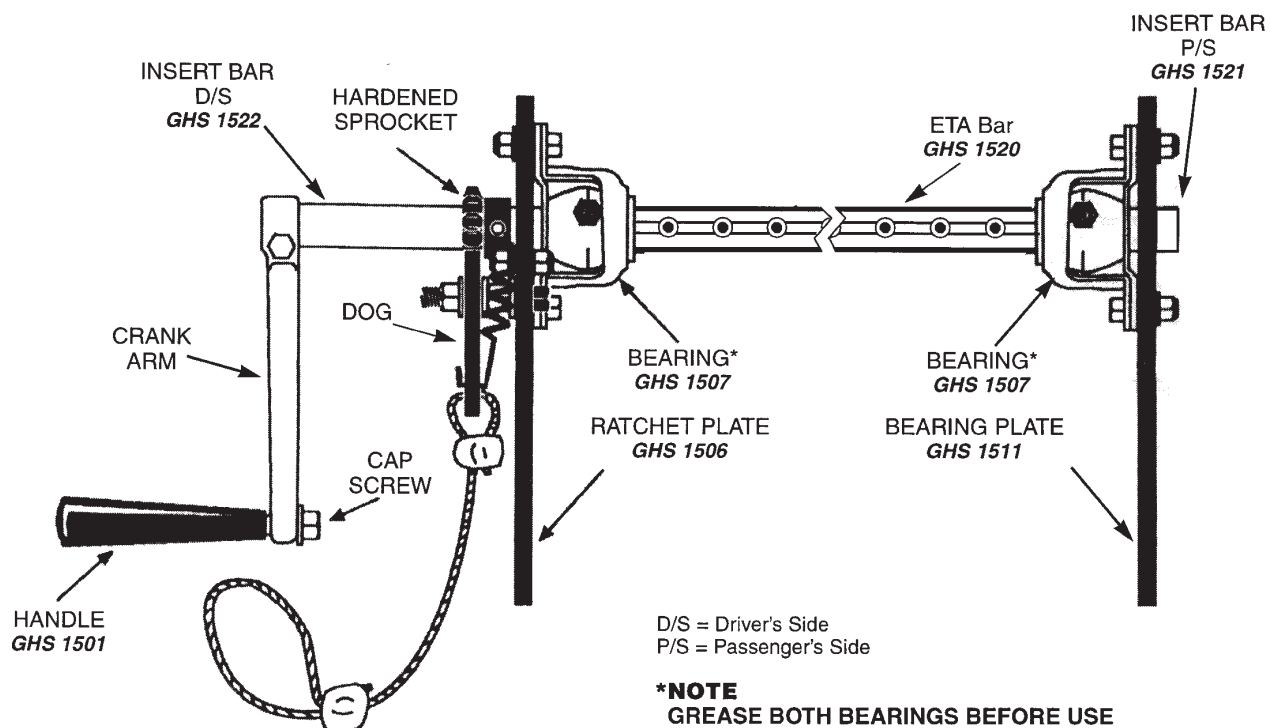
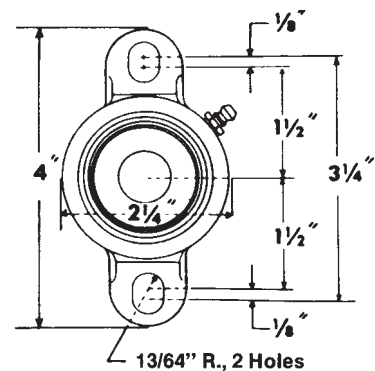

Open Mesh Tarps

FOR HAULING ROCK, SAND, & DEBRIS

"RHINO" MESH: 13 oz black PVC vinyl coated fabric

LEE STYLE tarps are designed for use on Steel Systems

- 7' wide by specified length (length of dump bed plus 2 ft)
- 6" pocket on one 7' end for wand cross bar
- Pocket lined for added strength
- 2 grommets in each pocket to prevent wear and sliding
- 5 grommets on other 7' end to attach to ETA Bar
- Grommets 30" on center on sides, for tarps 24' and longer
- Double stitched with UV polyester thread
- 800 lb per sq. in. webbing sewn onto front and side hems

| PART # | SIZE | WT/lb. |
|--------|----------|--------|
| LSM710 | 7' x 10' | 8 |
| LSM712 | 7' x 12' | 8.75 |
| LSM714 | 7' x 14' | 10.25 |
| LSM716 | 7' x 16' | 11.75 |
| LSM717 | 7' x 17' | 12 |
| LSM718 | 7' x 18' | 13 |
| LSM719 | 7' x 19' | 13.25 |
| LSM720 | 7' x 20' | 14 |
| LSM722 | 7' x 22' | 15 |
| LSM724 | 7' x 24' | 16.25 |
| LSM726 | 7' x 26' | 18 |
| LSM728 | 7' x 28' | 20 |
| LSM730 | 7' x 30' | 22 |
| LSM732 | 7' x 32' | 24 |



SEAMLESS ONE-PIECE CONSTRUCTION MEANS NO WELDED SEAMS TO PULL APART - BETTER DURABILITY

FOR HAULING ROCK, SAND, DEBRIS, AND ASPHALT

Lumite style fabric
100% black woven polypropylene

NOT completely waterproof, check your state for DOT approval.

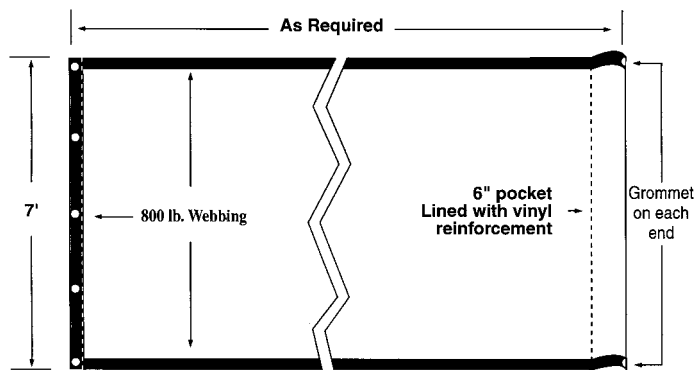

LEE STYLE tarps are designed for use on Steel Systems

- 7'6" wide by specified length (length of dump bed plus 2 ft)
- 6" pocket on one 7'6" end for wand cross bar
- Pocket lined for added strength
- 2 grommets in each pocket to prevent wear and sliding
- 5 grommets on other 7'6" end to attach to ETA Bar
- Grommets 30" on center on sides, for tarps 24' and longer
- Double stitched with UV polyester thread
- 800 lb per sq. in. webbing sewn onto front and side hems

| PART # | SIZE | WT/lb. |
|---------|------------|--------|
| LSL7610 | 7'6" x 10' | 6 |
| LSL7612 | 7'6" x 12' | 7 |
| LSL7614 | 7'6" x 14' | 8 |
| LSL7616 | 7'6" x 16' | 9 |
| LSL7617 | 7'6" x 17' | 9.5 |
| LSL7618 | 7'6" x 18' | 10 |
| LSL7619 | 7'6" x 19' | 10.5 |
| LSL7620 | 7'6" x 20' | 11 |
| LSL7622 | 7'6" x 22' | 11.5 |
| LSL7624 | 7'6" x 24' | 12 |
| LSL7626 | 7'6" x 26' | 14 |

Asphalt Tarps (waterproof)

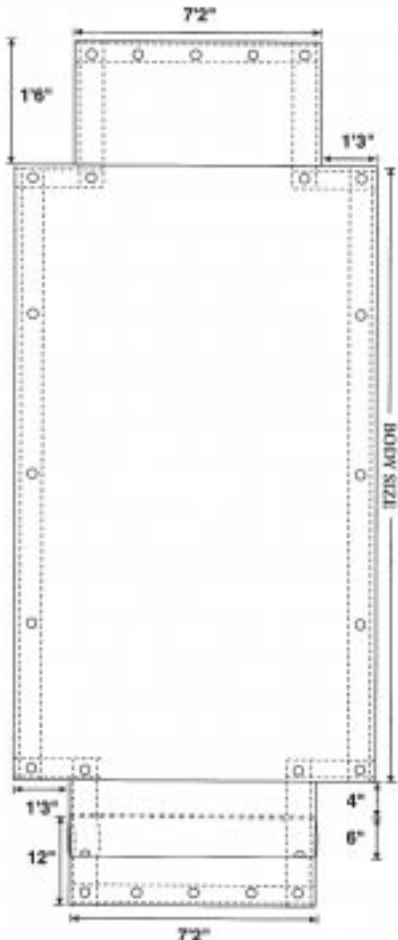
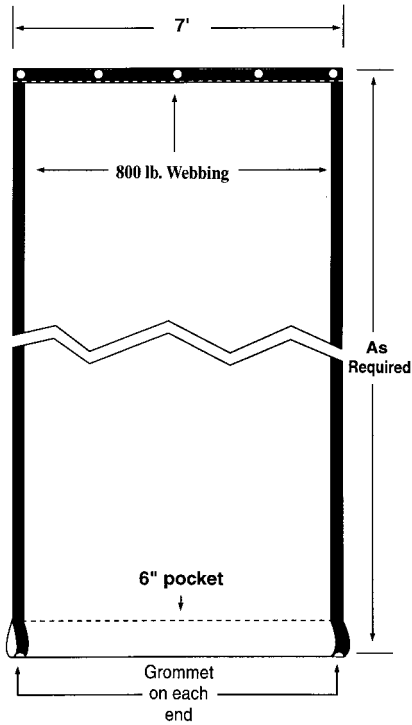

FOR HAULING ASPHALT

'ASPHALT PLUS' FABRIC - 14 oz waterproof vinyl - black

LEE STYLE tarps are designed for use on Steel Systems

- 7' wide by specified length (length of dump bed plus 2 ft)
- 6" pocket on one 7' end for wand cross bar
- 2 grommets in each pocket to prevent wear and sliding
- 5 grommets on other 7' end to attach to ETA Bar
- Grommets 30" on center on sides, for tarps 24' and longer
- Double stitched with UV polyester thread
- 800 lb per sq. in. webbing sewn onto front and side hems

| PART # | SIZE | WT/lb. |
|--------|----------|--------|
| LSA710 | 7' X 10' | 9 |
| LSA712 | 7' X 12' | 10 |
| LSA714 | 7' X 14' | 12 |
| LSA716 | 7' X 16' | 13 |
| LSA717 | 7' X 17' | 14 |
| LSA718 | 7' X 18' | 14.5 |
| LSA719 | 7' X 19' | 15 |
| LSA720 | 7' X 20' | 16 |
| LSA722 | 7' X 22' | 17 |
| LSA724 | 7' X 24' | 18 |
| LSA726 | 7' X 26' | 20 |

FOR HAULING ASPHALT

STANDARD ASPHALT TARP

State of Georgia D.O.T. compliant

14 oz waterproof 'Asphalt Plus' fabric - black

Built according to length of dump bed.

Side flaps and tail flap, pocket on tail flap.

| PART # | BED SIZE | WT/lb. |
|--------|----------|--------|
| AS150 | 15' | 27 |
| AS155 | 15'6" | 28 |
| AS160 | 16' | 29 |
| AS165 | 16'6" | 30 |
| AS170 | 17' | 31 |

All other bed sizes are considered 'custom' tarpaulins.

- Call For Prices -

KEEPS ASPHALT HOT AND DRY!

QUICK REFERENCE CHARTS FOR DUMP TRUCKS, STEEL SYSTEMS, AND TARPS

FOR HAULING ROCK, SAND, & DEBRIS

| TRUCK BODY | TARP | WIND-UP SYSTEM MANUAL | WIND-UP SYSTEM ELECTRIC | WAND SYSTEM |
|------------|--------|-----------------------|-------------------------|--------------------|
| 8' Bed | LSM710 | GHS 1500 | GHS 2500HT | *GHS 5050 Series |
| 10' Bed | LSM712 | GHS 1500 | GHS 2500HT | GHS 5050 Series |
| 12' Bed | LSM714 | GHS 1500 | GHS 2500HT | **GHS 5060 Series |
| 14' Bed | LSM716 | GHS 1500 | GHS 2500HT | GHS 5060 Series |
| 15' Bed | LSM717 | GHS 1500 | GHS 2500HT | GHS 5060 Series |
| 16' Bed | LSM718 | GHS 1500 | GHS 2500HT | GHS 5060 Series |
| 17' Bed | LSM719 | GHS 1500 | GHS 2500HT | GHS 5060 Series |
| 18' Bed | LSM720 | GHS 1500 | GHS 2500HT | GHS 5060 Series |
| 20' Bed | LSM722 | GHS 1500 | GHS 2500HT | ***GHS 5070 Series |
| 22' Bed | LSM724 | GHS 1500 | GHS 3500HT | GHS 5070 Series |
| 24' Bed | LSM726 | GHS 1500 | GHS 3500HT | GHS 5070 Series |

- * Includes GHS 5050, GHS 5050-A, GHS 5050LS and GHS 5050LS-A
- ** Includes GHS 5060, GHS 5060-A, GHS 5060LS and GHS 5060LS-A
- *** Includes GHS 5070 and GHS 5070-A

FOR HAULING ROCK, SAND, DEBRIS, & ASPHALT

| TRUCK BODY | TARP | WIND-UP SYSTEM MANUAL | WIND-UP SYSTEM ELECTRIC | WAND SYSTEM |
|------------|---------|-----------------------|-------------------------|--------------------|
| 8' Bed | LSL7610 | GHS 1500 | GHS 2500HT | *GHS 5050 Series |
| 10' Bed | LSL7612 | GHS 1500 | GHS 2500HT | GHS 5050 Series |
| 12' Bed | LSL7614 | GHS 1500 | GHS 2500HT | **GHS 5060 Series |
| 14' Bed | LSL7616 | GHS 1500 | GHS 2500HT | GHS 5060 Series |
| 15' Bed | LSL7617 | GHS 1500 | GHS 2500HT | GHS 5060 Series |
| 16' Bed | LSL7618 | GHS 1500 | GHS 2500HT | GHS 5060 Series |
| 17' Bed | LSL7619 | GHS 1500 | GHS 2500HT | GHS 5060 Series |
| 18' Bed | LSL7620 | GHS 1500 | GHS 2500HT | GHS 5060 Series |
| 20' Bed | LSL7622 | GHS 1500 | GHS 2500HT | ***GHS 5070 Series |
| 22' Bed | LSL7624 | GHS 1500 | GHS 3500HT | GHS 5070 Series |
| 24' Bed | LSL7626 | GHS 1500 | GHS 3500HT | GHS 5070 Series |

- * Includes GHS 5050, GHS 5050-A, GHS 5050LS and GHS 5050LS-A
- ** Includes GHS 5060, GHS 5060-A, GHS 5060LS and GHS 5060LS-A
- *** Includes GHS 5070 and GHS 5070-A

Quick Reference Charts

QUICK REFERENCE CHARTS FOR DUMP TRUCKS, STEEL SYSTEMS, AND TARPS

FOR HAULING ASPHALT

| TRUCK BODY | TARP | WIND-UP SYSTEM MANUAL | WIND-UP SYSTEM ELECTRIC | WAND SYSTEM |
|------------|--------|-----------------------|-------------------------|--------------------|
| 8' Bed | LSA710 | GHS 1500 | GHS 2500HT | *GHS 5050 Series |
| 10' Bed | LSA712 | GHS 1500 | GHS 2500HT | GHS 5050 Series |
| 12' Bed | LSA714 | GHS 1500 | GHS 2500HT | **GHS 5060 Series |
| 14' Bed | LSA716 | GHS 1500 | GHS 2500HT | GHS 5060 Series |
| 15' Bed | LSA717 | GHS 1500 | GHS 2500HT | GHS 5060 Series |
| 16' Bed | LSA718 | GHS 1500 | GHS 2500HT | GHS 5060 Series |
| 17' Bed | LSA719 | GHS 1500 | GHS 2500HT | GHS 5060 Series |
| 18' Bed | LSA720 | GHS 1500 | GHS 2500HT | GHS 5060 Series |
| 20' Bed | LSA722 | GHS 1500 | GHS 2500HT | ***GHS 5070 Series |
| 22' Bed | LSA724 | GHS 1500 | GHS 3500HT | GHS 5070 Series |
| 24' Bed | LSA726 | GHS 1500 | GHS 3500HT | GHS 5070 Series |

* Includes GHS 5050, GHS 5050-A, GHS 5050LS and GHS 5050LS-A

** Includes GHS 5060, GHS 5060-A, GHS 5060LS and GHS 5060LS-A

*** Includes GHS 5070 and GHS 5070-A

FOR HAULING ASPHALT - WATERPROOF COVER

Georgia State **DOT Style** compliant tarpaulin with flaps

| TRUCK BODY | TARP | WIND-UP SYSTEM MANUAL | WIND-UP SYSTEM ELECTRIC | WAND SYSTEM |
|------------|-------|-----------------------|-------------------------|--------------------|
| 8' Bed | **** | GHS 1500 | GHS 2500HT | *GHS 5050 Series |
| 10' Bed | **** | GHS 1500 | GHS 2500HT | GHS 5050 Series |
| 12' Bed | **** | GHS 1500 | GHS 2500HT | **GHS 5060 Series |
| 14' Bed | **** | GHS 1500 | GHS 2500HT | GHS 5060 Series |
| 15' Bed | AS150 | GHS 1500 | GHS 2500HT | GHS 5060 Series |
| 15'6" Bed | AS155 | GHS 1500 | GHS 2500HT | GHS 5060 Series |
| 16' Bed | AS160 | GHS 1500 | GHS 2500HT | GHS 5060 Series |
| 16'6" Bed | AS165 | GHS 1500 | GHS 2500HT | GHS 5060 Series |
| 17' Bed | AS170 | GHS 1500 | GHS 2500HT | GHS 5060 Series |
| 18' Bed | **** | GHS 1500 | GHS 2500HT | GHS 5060 Series |
| 20' Bed | **** | GHS 1500 | GHS 2500HT | ***GHS 5070 Series |
| 22' Bed | **** | GHS 1500 | GHS 3500HT | GHS 5070 Series |

* Includes GHS 5050, GHS 5050-A, GHS 5050LS and GHS 5050LS-A

** Includes GHS 5060, GHS 5060-A, GHS 5060LS and GHS 5060LS-A

*** Includes GHS 5070 and GHS 5070-A

**** Special order these sizes

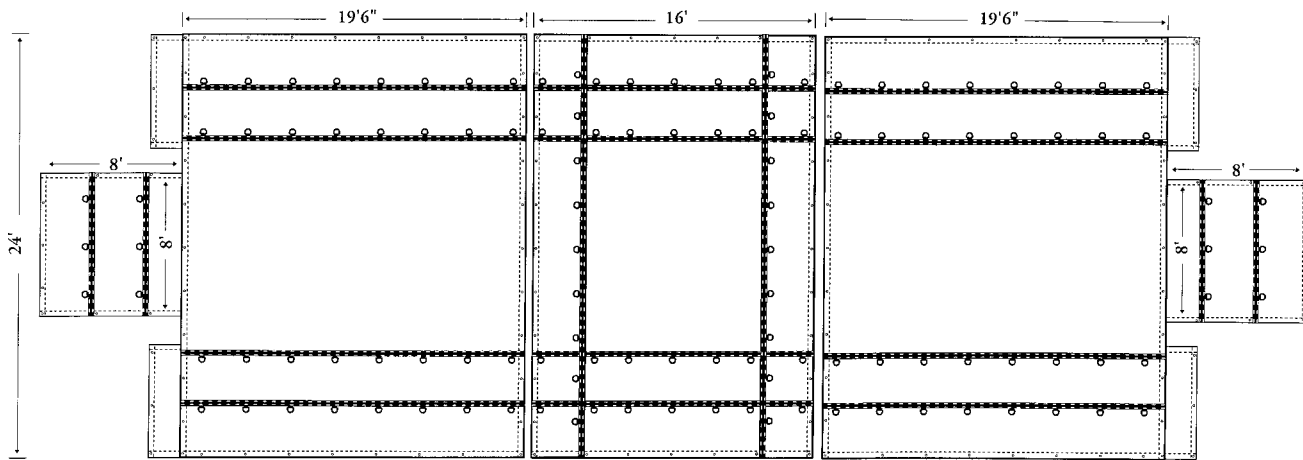

THREE-PIECE LUMBER TARP PART# SL18B

- 8' drops
- For trailers up to 48'
- Made from 18 oz black vinyl coated fabric - waterproof
- Grommets and dee rings 30" on center
- Finished size:
 - 2 end pieces: 24' x 19'6" with 8' x 8' tail 83 lb ea.
 - 1 center piece: 24' x 16' 63 lb ea.
- Dee bands:
 - ends: 3' and 6' up 19'6" sides and tail
 - center: 3' and 6' up 16' sides and 3' up 24' sides

Black is our stock color - other colors or combination of colors available. Call for prices.

SUPERIOR CONSTRUCTION

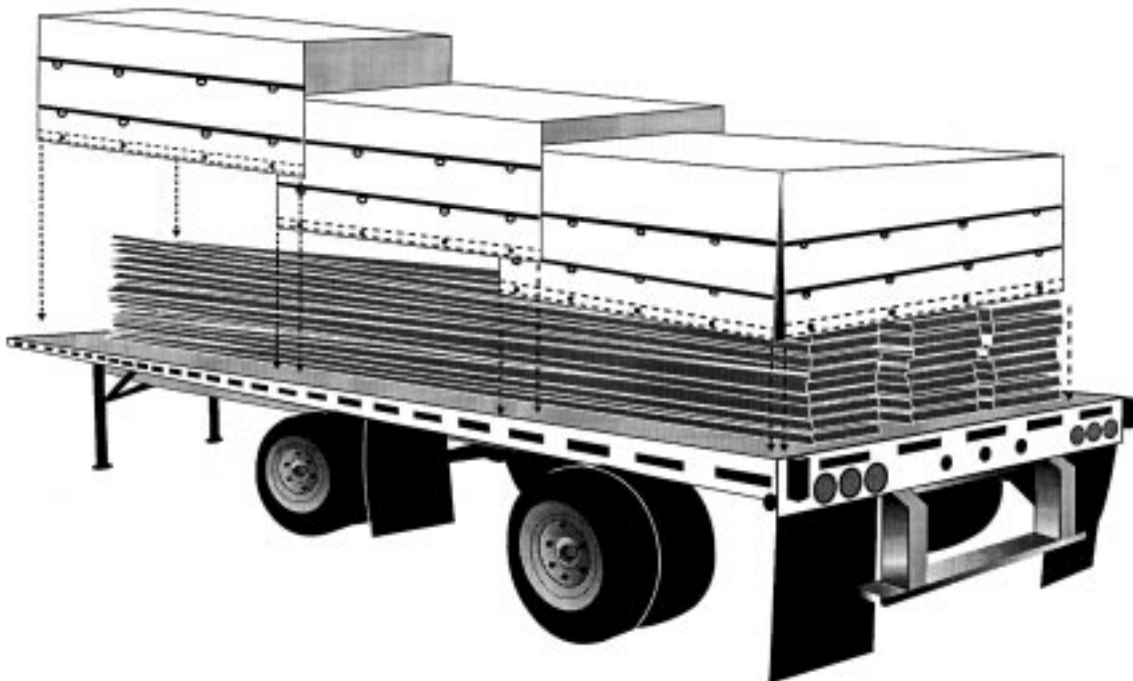
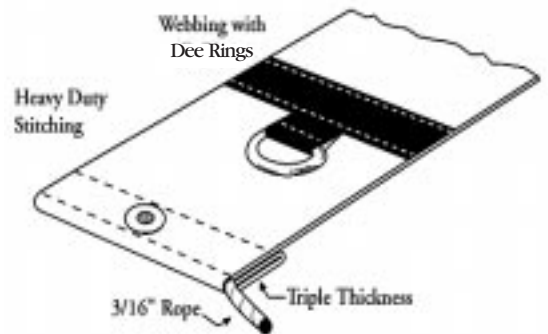

Tarpaulins

FLANGED TARPS

STANDARD LUMBER TARP

PART #SL18 2-PIECE SET

- 8' drops
- For trailers up to 48'
- Made from 18 oz black vinyl coated fabric - waterproof
- Grommets and dee rings 30" on center
- Finished size:
 - 24' x 26' with 8' x 8' tail - 103 lbs ea.
- Dee bands:
 - 3' and 6' up each 26' side and on tail

Black is our stock color.
Other colors or combination of
colors available. Call for prices.

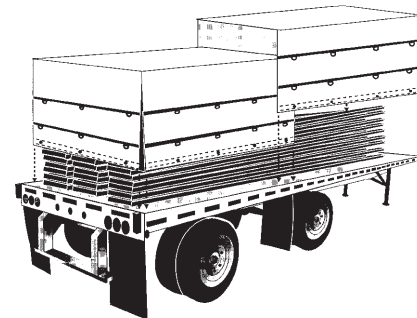
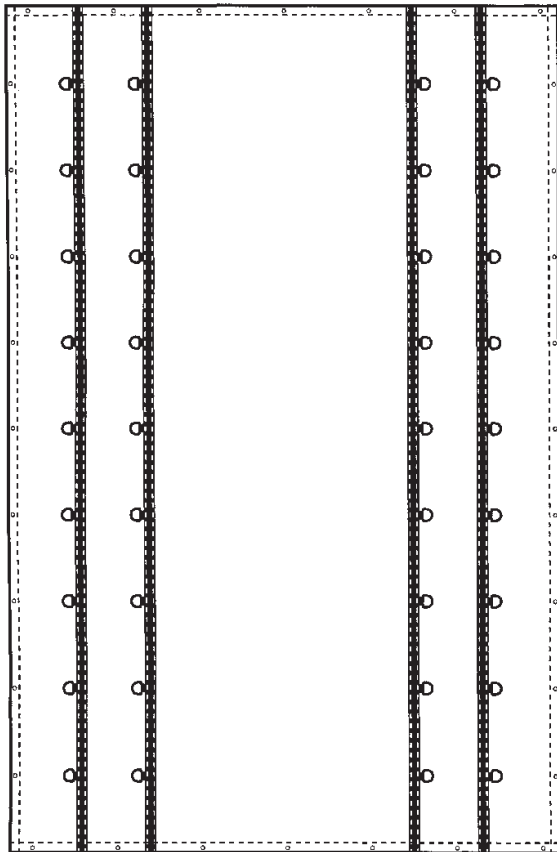
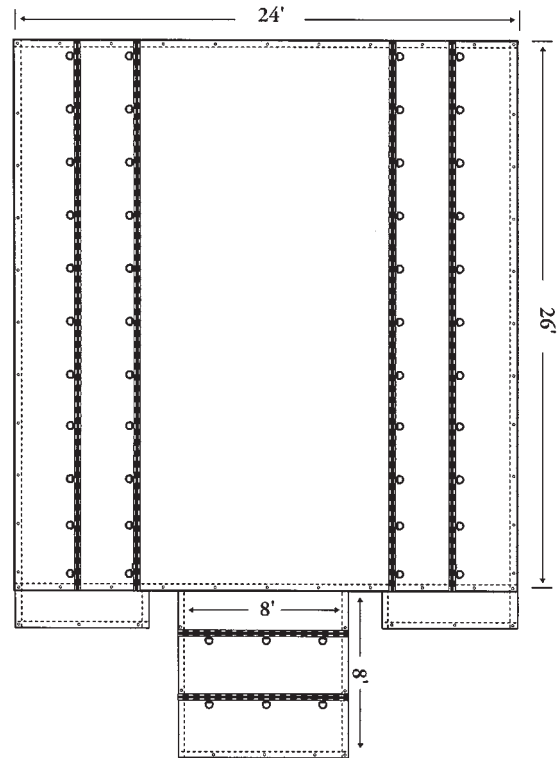

STANDARD STEEL TARP

PART# SS18 2-PIECE SET

- 4' drops
- Made from 18 oz black vinyl coated fabric - waterproof
- Grommets and dee rings 30" on center
- Finished size:
 - 16' x 24'6" - 63 lbs ea.
- Dee bands:
 - 2' and 4' up each 24'6" length

Black is our stock color.
Other colors or combination of
colors available. Call for prices.

COIL COVERS

- Made from black vinyl coated fabric in 18 oz or 22 oz
- Triple rolled hem
- Double stitched
- #4 brass grommets 2' on center on hems
- Dee band 2' up from hem on all sides
- Dee rings 2' on center

Black is our stock color.
Other colors are available. Call for prices.

| PART # | DESCRIPTION |
|--------|---|
| CCS18 | Single Coil Cover 18 oz vinyl 5x5x5 |
| CCD18 | Double Coil Cover 18 oz vinyl 5x5x12 |
| CCS22 | Single Coil Cover 22 oz vinyl 5x5x5 |
| CCD22 | Double Coil Cover 22 oz vinyl 5x5x12 |

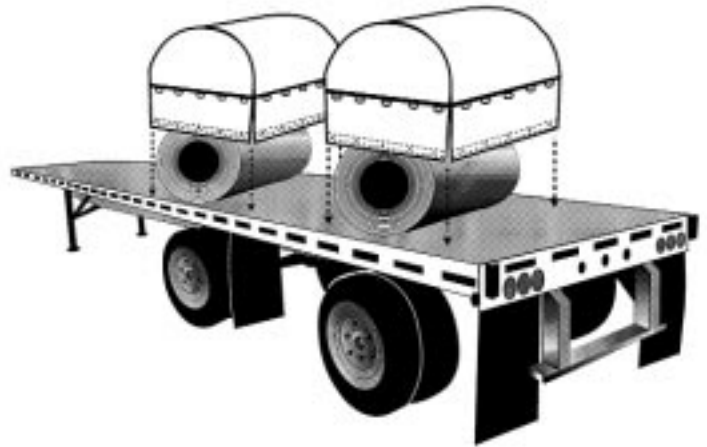
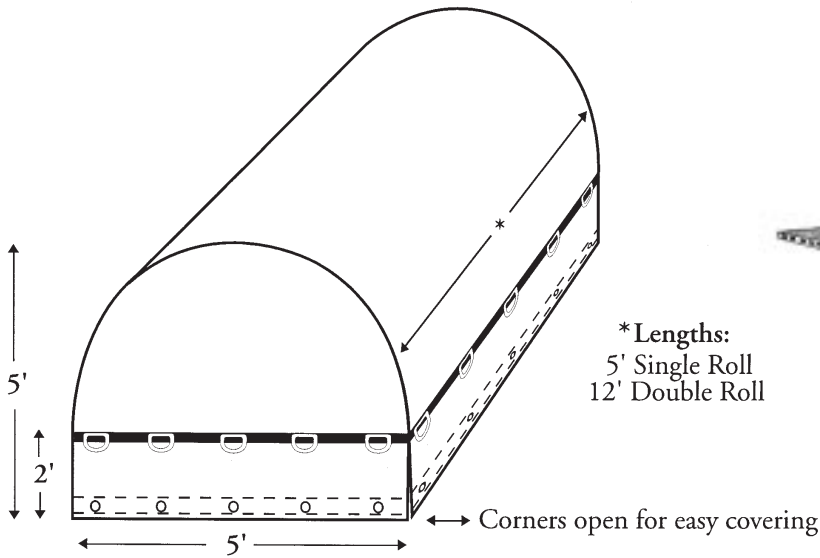

NOSE TARPS (SMOKE TARPS)

- 18 oz black vinyl coated fabric
- Finished size 10' x 12'
- #4 brass grommets 2' on center

Black is our stock color.
Other colors are available. Call for prices.

| PART # | DESCRIPTION |
|---------|----------------------------|
| SNT18-F | Flat tarp 10'X12' |
| SNT18-B | Boxed on top with 2' drops |

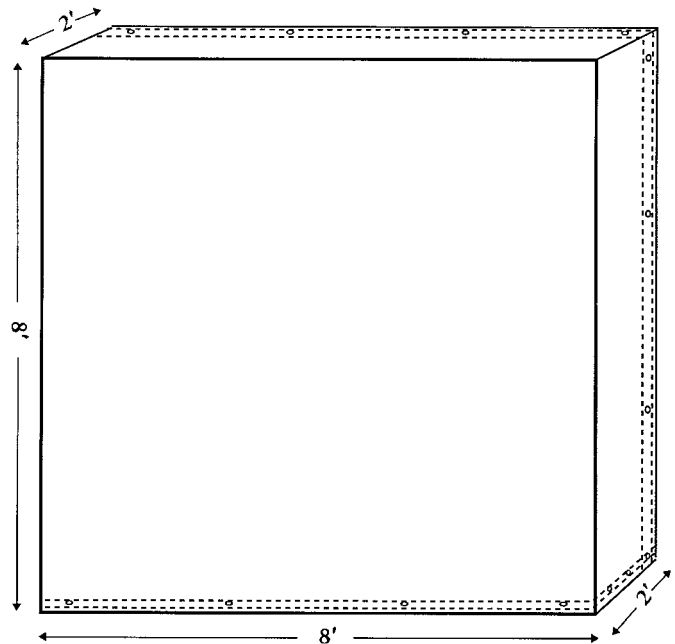

SNT18-B

Tarpaulins

TRAILER TARPS



SIDE KIT TARPS

Side kit tarps are made finished size with triple rolled hems, 18" drop, full tail and gussets. Tail size is 4'9" x 8'. Grommets are 2' on center on tarp body and 1' on center on tail. For dee rings add 5%.

| 18 oz VINYL COATED FABRIC | | | |
|---------------------------|-----------------|-----------------|-----------------|
| Trailer Length | 18" Rise Part # | 24" Rise Part # | 30" Rise Part # |
| 28' | SK18-28-18 | SK18-28-24 | SK18-28-30 |
| 32' | SK18-32-18 | SK18-32-24 | SK18-32-30 |
| 36' | SK18-36-18 | SK18-36-24 | SK18-36-30 |
| 38' | SK18-38-18 | SK18-38-24 | SK18-38-30 |
| 40' | SK18-40-18 | SK18-40-24 | SK18-40-30 |
| 42' | SK18-42-18 | SK18-42-24 | SK18-42-30 |
| 45' | SK18-45-18 | SK18-45-24 | SK18-45-30 |
| 48' | SK18-48-18 | SK18-48-24 | SK18-48-30 |

| 22 oz VINYL COATED FABRIC | | | |
|---------------------------|-----------------|-----------------|-----------------|
| Trailer Length | 18" Rise Part # | 24" Rise Part # | 30" Rise Part # |
| 28' | SK22-28-18 | SK22-28-24 | SK22-28-30 |
| 32' | SK22-32-18 | SK22-32-24 | SK22-32-30 |
| 36' | SK22-36-18 | SK22-36-24 | SK22-36-30 |
| 38' | SK22-38-18 | SK22-38-24 | SK22-38-30 |
| 40' | SK22-40-18 | SK22-40-24 | SK22-40-30 |
| 42' | SK22-42-18 | SK22-42-24 | SK22-42-30 |
| 45' | SK22-45-18 | SK22-45-24 | SK22-45-30 |
| 48' | SK22-48-18 | SK22-48-24 | SK22-48-30 |

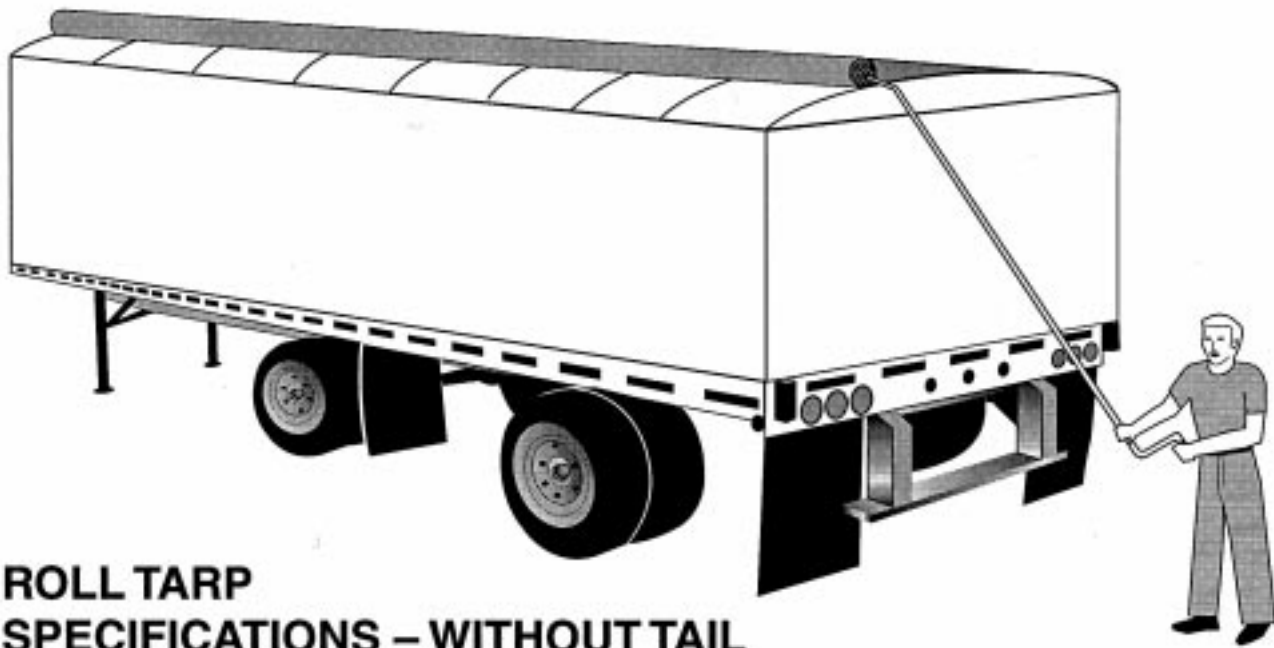

ROLL TARP SPECIFICATIONS – WITHOUT TAIL

(Fill in your dimensions)

A _____

B _____

PSP _____

Pipe Size _____

DSP _____

Pipe Size _____

WR: YES (standard spacing is 30" apart)

NO

18 oz. 22 oz.

FABRIC COLOR _____

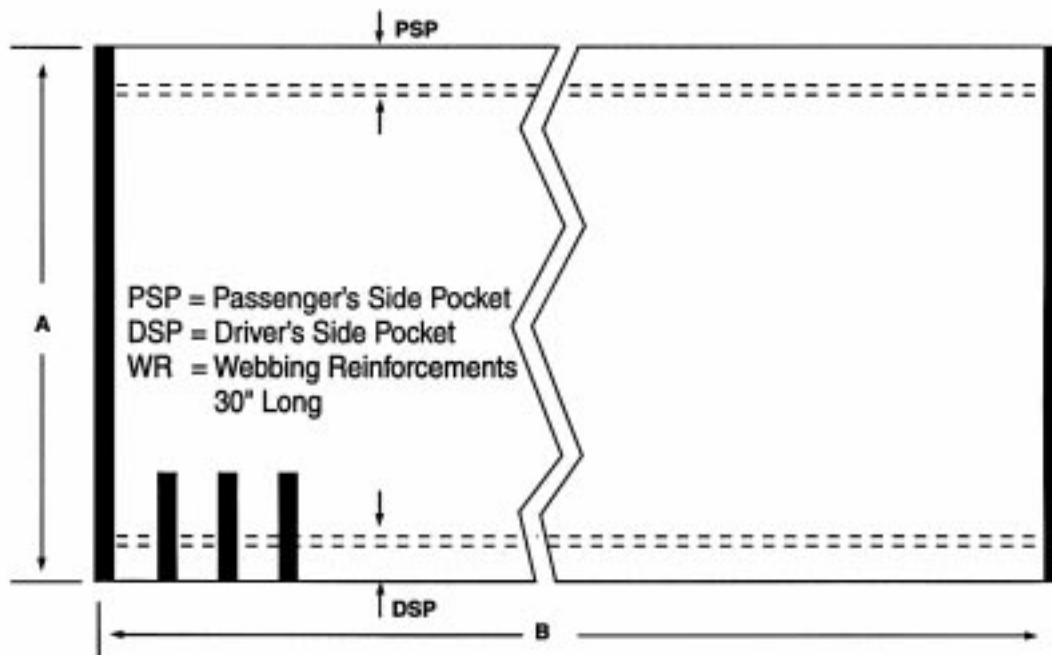

Tarpaulins

TRAILER TARPS

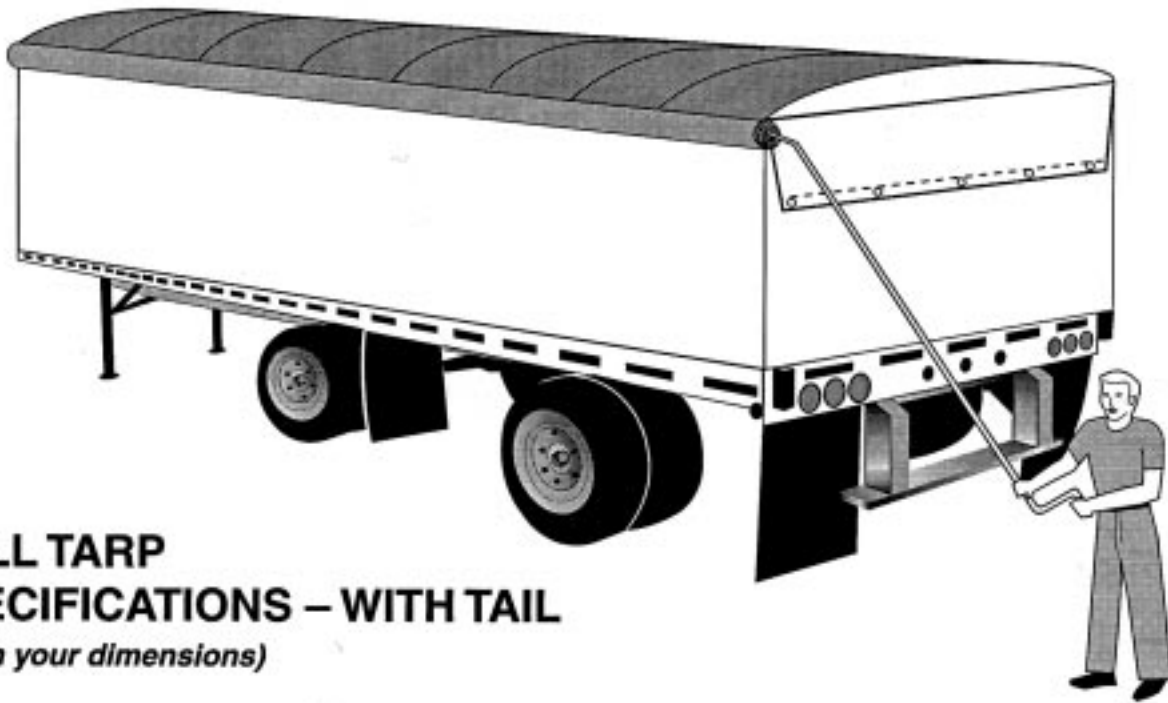

ROLL TARP SPECIFICATIONS – WITH TAIL

(Fill in your dimensions)

A _____
 B _____
 C _____
 D _____
 E _____
 F _____
 G _____

PSP _____

Pipe Size _____

DSP _____

Pipe Size _____

WR: YES (standard spacing is 30" apart)
 NO

18 oz. 22 oz.

FABRIC COLOR _____

TAIL: WITH GROMMETS

WITH DEE RINGS

SPACING _____" on center
 (standard spacing is 30" apart)

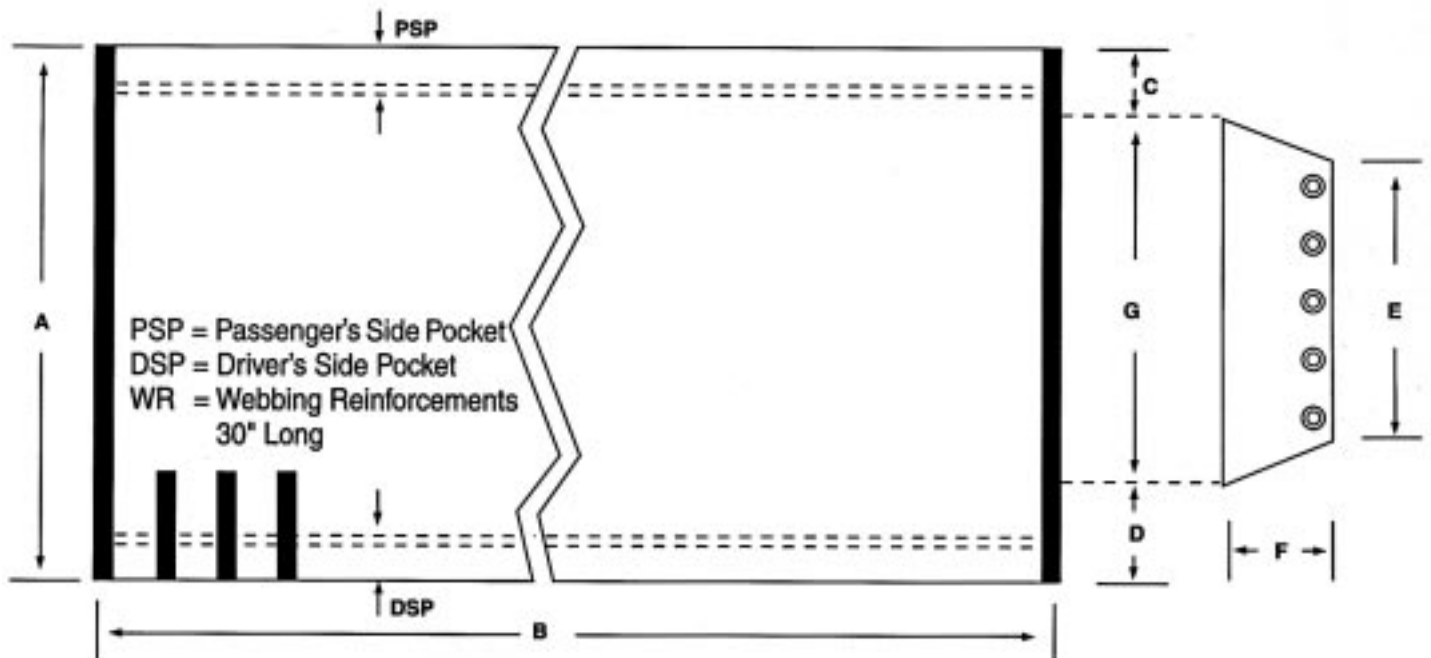

ROLL TARP – FITTED NOSE

(Fill in your dimensions)

18 oz. 22 oz.

FABRIC COLOR _____

A Front Drop _____

B Passenger's Side Drop _____

C Driver's Side Drop _____

D Passenger's Side Pocket Size _____

Pipe Size _____

Rope Size _____

E Driver's Side Pocket Size _____

Pipe Size _____

Rope Size _____

W Body Width _____

L Body Length _____

G Wide Part of Tail _____

H Narrow Part of Tail _____

I Tail to Pocket "D" _____

J Tail to Pocket "E" _____

WITH GROMMETS

SPACING _____" on center

WITH DEE RINGS

SPACING _____" on center

(standard spacing is 30" apart)

TT Tail Taper _____

K Tail Drop _____

R Radius _____

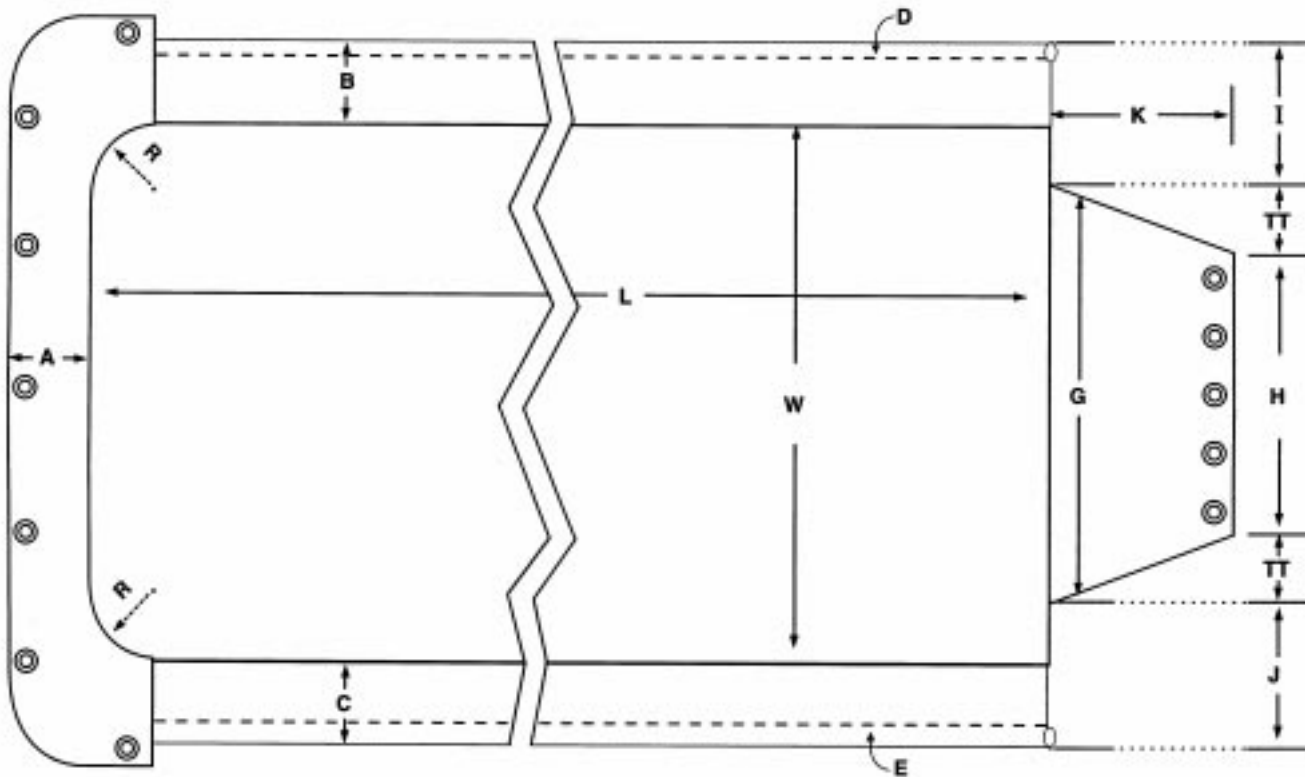
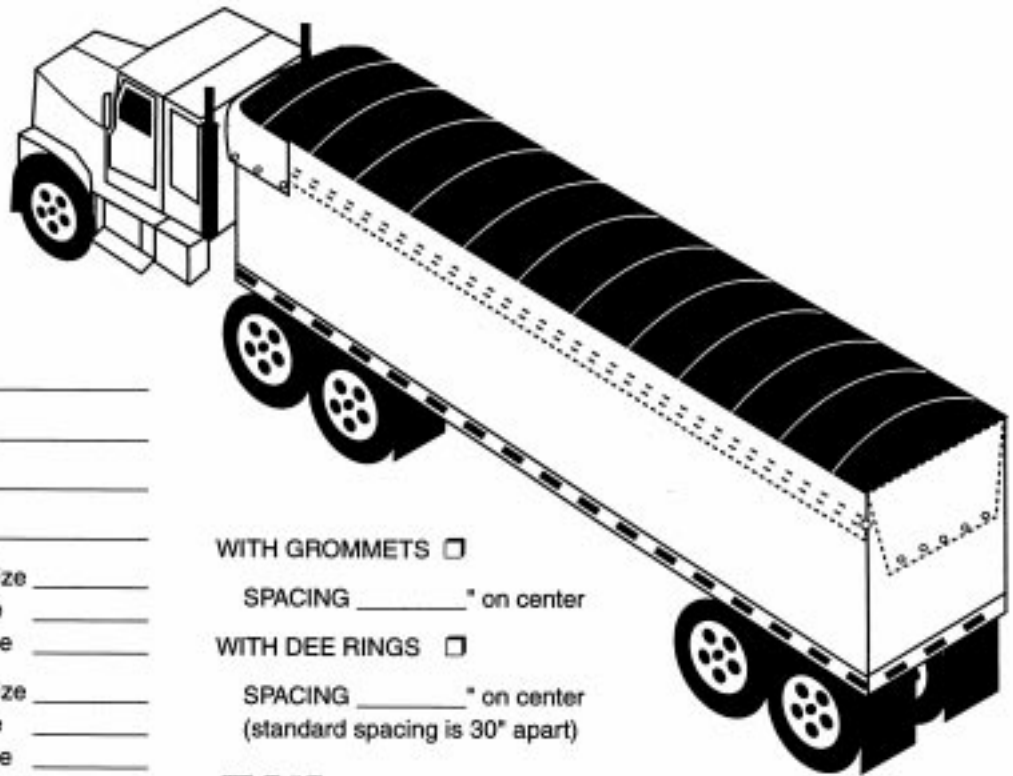

Tarpaulins

REFUSE TARPS

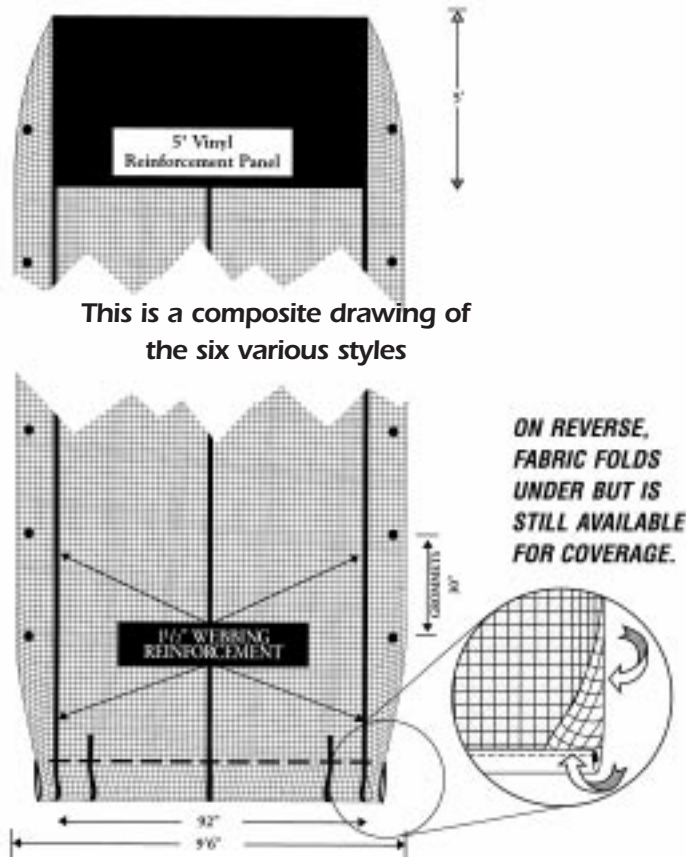

This is a composite drawing of the six various styles

REFUSE COVERS FOR TOMATIC COVERING SYSTEMS

Standard size: 9'6" X 28' with automatic folding sideflaps enforced with 800 lb per square inch webbing duty black "Rhino" Mesh



ON REVERSE, FABRIC FOLDS UNDER BUT IS STILL AVAILABLE FOR COVERAGE.

| PART # | SIX STYLES AVAILABLE |
|------------------|--|
| ACVR1-OB | FOR O'BRIAN SYSTEM. Vinyl reinforcement on each end. Pocket on one end. No grommets on the other end. |
| ACWR2-OB | FOR O'BRIAN SYSTEM. Webbing reinforcement, no vinyl. Pocket on one end. No grommets on the other end. |
| ACVR1-BB | FOR B&B EQUIPMENT SYSTEM. Vinyl reinforcement on each end. Pocket on both ends. |
| ACWR2-BB | FOR B&B EQUIPMENT SYSTEM. Webbing reinforcement, no vinyl. Pocket on both ends. |
| ACVR1-PRM | FOR PIONEER ROLL-MASTER SYSTEM. Vinyl reinforcement on each end. Grommets 12" on center on both ends. No pockets. |
| ACWR2-PRM | FOR PIONEER ROLL-MASTER SYSTEM. Webbing reinforcement, no vinyl. Grommets 12" on center on both ends. No pockets. |

| PART # | DESCRIPTION |
|---------|---|
| | <p>DIAPERS</p> <ul style="list-style-type: none"> ▪ Cut size tarps for chute end of enclosed containers ▪ Multi-color mesh ▪ Triple rolled hem ▪ Grommets 2' on center |
| DPR57 | Cut Size: 5' x 7' |
| DPR68 | Cut Size: 6' x 8' |
| | <p>THROW TARPS</p> <ul style="list-style-type: none"> ▪ Cut size tarps for open containers ▪ Multi-colored mesh ▪ Triple rolled hem ▪ Grommets 30" on center |
| MET1218 | Cut Size: 12' x 18' |
| MET1224 | Cut Size: 12' x 24' |
| MET1225 | Cut Size: 12' x 25' |
| MET1226 | Cut Size: 12' x 26' |
| MET1043 | Cut Size: 10' x 43' |
| MET1045 | Cut Size: 10' x 45' |
| | <p>THROW TARPS</p> <p>Manufactured the same as the above, with vinyl reinforcements added. These squares of vinyl line up with the corners of typical containers to help prevent snagging and tearing.</p> |
| MER1224 | Cut Size: 12' x 24' |
| MER1225 | Cut Size: 12' x 25' |
| MER1226 | Cut Size: 12' x 26' |

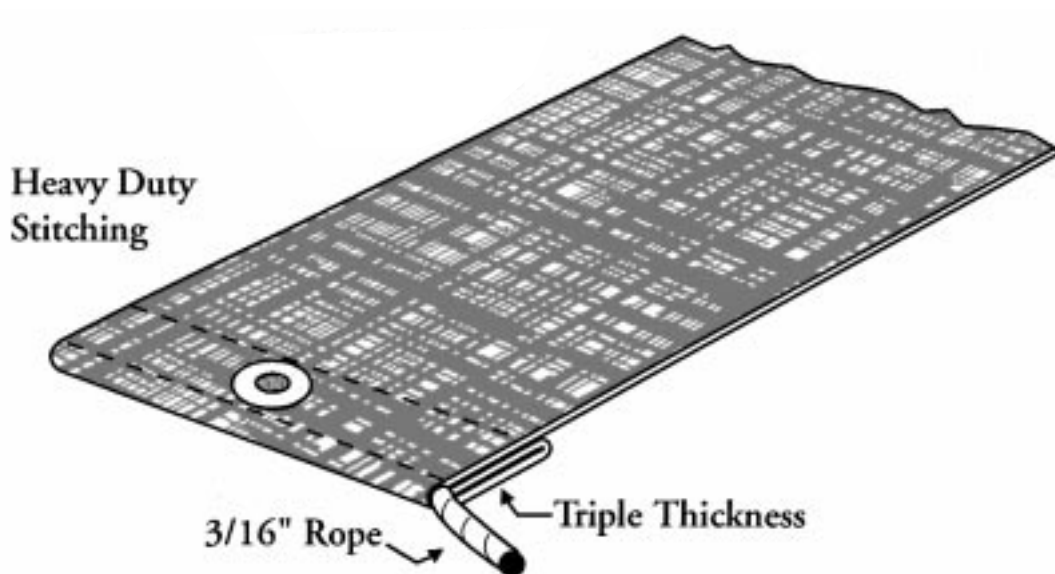

Tarpaulins

MESH - NOT WATERPROOF

Multi-color mesh is recommended for most waste applications, tree hauling, landscape tarps, and throw tarps. Good general purpose fabric for container loads. Least expensive of the mesh fabrics.

- 11 x 11 thread count per square inch
- 1000 Denier yarn
- 10 oz. per square yard fabric
- Each yarn is coated with PVC before weaving for abrasion and UV resistance.

Black 'Rhino' mesh is recommended for rock, sand and gravel tarps, sod tarps, automatic refuse cover tarps, and open top trailers.

- 40% stronger than multi-color mesh
- 11 x 11 thread count per square inch
- 1430 Denier yarn
- 13 oz per square yard fabric
- Each yarn is coated with PVC before weaving

Green 'Tiger' mesh is recommended for tree hauling, landscape tarps, open top trailers, and hot shot lumber style tarps.

- 9 x 9 thread count per square inch
- 1430 Denier yarn
- 12 oz per square yard fabric
- Each yarn is coated with PVC before weaving

Black 'Lumite' mesh is recommended for asphalt hauling when a waterproof cover is not needed, and for hauling rock, sand, and gravel.

- 100% woven Polypropylene
- Very lightweight fabric, 4.5 oz per square yard
- Moderate abrasion and tear strength

VINYL COATED FABRIC - WATERPROOF

14 oz 'Asphalt Plus': Special compound added to PVC formula to resist the sticking of asphalt.

14 oz vinyl coated polyester: A lightweight vinyl that lends itself well for use on a tarping system.

18 oz vinyl coated polyester: Most commonly used for over-the-road protective covers such as steel, lumber, or grain covers. Has a high tear strength and moderate to heavy abrasion resistance.

22 oz vinyl coated polyester: Approximately 25% stronger than 18 oz vinyl. Recommended for the same applications as 18 oz vinyl, but where a higher abrasion and tear resistance is indicated.

CUSTOM TARPS

**Roll Tarps • Fitted Tarps • Sod Tarps • Tree Tarps • Cable Tarps
Throw Tarps • Mesh 'Hot Shot' Tarps**

Materials:

- **MESH:** Multi-color, Black, and Green
- **18 oz VINYL:** Black, Blue, Green, Red, White, Yellow, Gray, and Orange
- **22 oz VINYL:** Black, Green, and Blue

Construction:

- All hems are triple rolled with rope sewn inside for additional strength
- All grommets are heavy duty brass #4 teeth washers
- All dee rings are attached to the tarp with double sewn webbing reinforcements
- All vinyl materials are welded together by our state-of-the-art vinyl sealer, making the joined area stronger than the original material
- All sewing is lock stitched for better security, and only polyester thread is used for durability
- All tarps are made to the full finished size - not cut size

Note: Unless otherwise specified, all grommets and dee rings are on 30" centers.



Courtesy of Red Man Trucking

Superior Construction

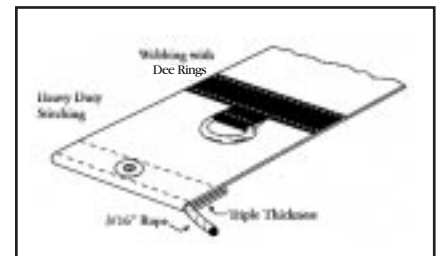

Special Requests:

- Stenciling available with customer logo. Call customer service for details.
- Stenciling is available using 6" block letters.
- Other materials available include: velcro, clear vinyl, fire retardant vinyl, laminates, and more.

Custom tarps are not returnable. Drawings must accompany custom tarp orders.

Accessories

ACCESSORIES



RUBBER STRAPS

Designed to hold tarps securely in place, not to hold loads in place.

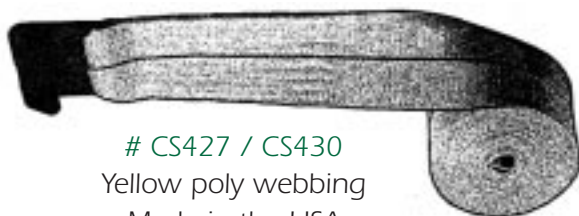

CS427 / CS430
Yellow poly webbing
Made in the USA

RUBBER TARPAULIN STRAPS

- American made
- Heavy duty
- Tear drop end
- Molded from high-grade EPDM compound
- S-hooks are zinc-plated steel and already installed
- Resists oxidation, heat, and cold crack
- Sold in full cases only

| PART # | STRAP SIZE | CASE QTY | MAX STRETCH |
|--------|------------|----------|-------------|
| RS10 | 10" | 50 | up to 17" |
| RS15 | 15" | 50 | up to 26" |
| RS21 | 21" | 50 | up to 36" |
| RS31 | 31" | 50 | up to 53" |
| RS41 | 41" | 25 | up to 70" |



CS227 / CS230
Yellow poly webbing / Made in the USA

| CARGO CONTROL SYSTEMS | |
|-----------------------|--|
| PART # | DESCRIPTION |
| CS227 | 2" x 27' Ratchet Buckle Strap Assembly. Flat hook on each end, standard handle. 10,000 lb capacity. California rated and approved. |
| CS230 | 2" x 30' as above. |
| CS427 | 4" x 27' Load Binder Strap with flat hook on one end. 15,000 lb capacity - California rated and approved. |
| CS430 | 4" x 30' as above. |
| CSWW | Weld on Winch for 3" and 4" straps. Fully slotted mandrel. Holds approximately 30' of webbing. |
| CSPW | Portable Winch with 2 set screws. Fully slotted mandrel. Holds approximately 30' of webbing. |
| CSWB | Winch Bar - chrome finish. Non-slip handle, 33" length. |



CSWB



CSWW

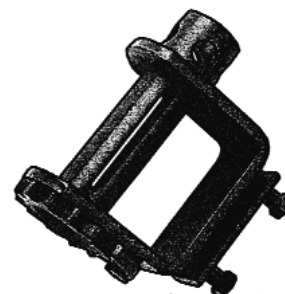

CSPW



VINYL CEMENT

| <u>PART #</u> | <u>DESCRIPTION</u> |
|---------------|--|
| HH66-Q | HH66 quart (brush-top can) |
| HH66-G | HH66 gallon |
| | <u>REPAIR KIT</u> |
| KIT | 1 quart HH66 vinyl cement and 1 yard 18 oz vinyl fabric (standard fabric colors available) |

Even the finest tarpaulin fabrics will require repair from time to time. This repair kit is provided for your convenience in minor roadside repairs.

- EXCEPTIONAL BOND STRENGTH
- EASY APPLICATION - brushes on smoothly, quickly
- FAST DRYING - ready in minutes
- WATERPROOF - outstanding resistance to temperature and weather extremes, chemicals, oil, fuel, grease
- VERSATILE - use for fabricating, repairing, sealing stitched seams - remains flexible
- LONG MILEAGE, LONG SHELF LIFE

HH-66: The Problem Solver

Cut size tarps hemmed with 2 3/4" black polypropylene webbing and #2 brass grommets 30" on center

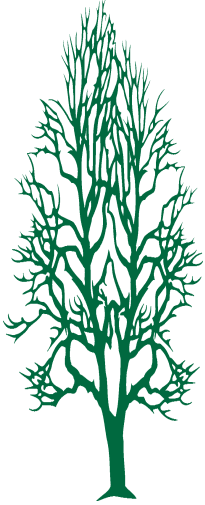

MULTI-COLOR MESH

| PART # | CUT SIZE |
|---------|----------|
| NMM0608 | 6 x 8 |
| NMM0810 | 8 x 10 |
| NMM0812 | 8 x 12 |
| NMM0818 | 8 x 18 |
| NMM1214 | 12 x 14 |
| NMM1220 | 12 x 20 |
| NMM1224 | 12 x 24 |
| NMM1226 | 12 x 26 |
| NMM1824 | 18 x 24 |

GREEN 'TIGER' MESH

| PART # | CUT SIZE |
|---------|----------|
| NTM0608 | 6 x 8 |
| NTM0810 | 8 x 10 |
| NTM0812 | 8 x 12 |
| NTM0818 | 8 x 18 |
| NTM1214 | 12 x 14 |
| NTM1220 | 12 x 20 |
| NTM1224 | 12 x 24 |
| NTM1226 | 12 x 26 |
| NTM1824 | 18 x 24 |

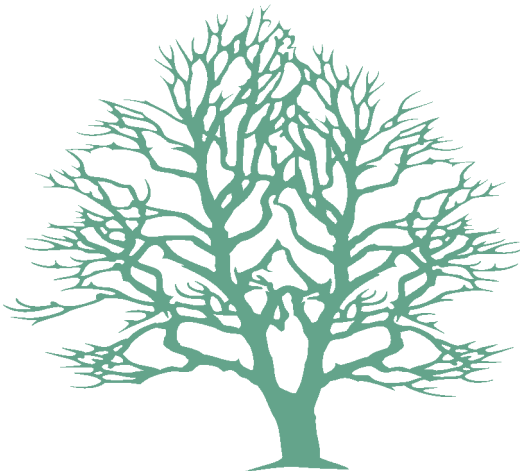

Photo courtesy of Pike Family Nursery

SHADE CLOTH

ALL ORDERS ARE CUSTOM MADE TO YOUR SPECIFICATIONS

- Black woven polypropylene
- Shade factors available:
 - 30% 63%
 - 47% 73%
 - 55% 80%
 - 95%
- Roll goods available
 - Widths 6', 10', and 12'
 - Lengths 100 yds and 500 yds



Blue 'Poly' Tarps - See Page 24
Silver/Black 'Poly' Tarps - See Page 25
Rubber Straps - See Page 21



"BLUE POLY TARPS"

BLUE POLY TARPS



2.75 oz./8 x 8 Tarp Construction

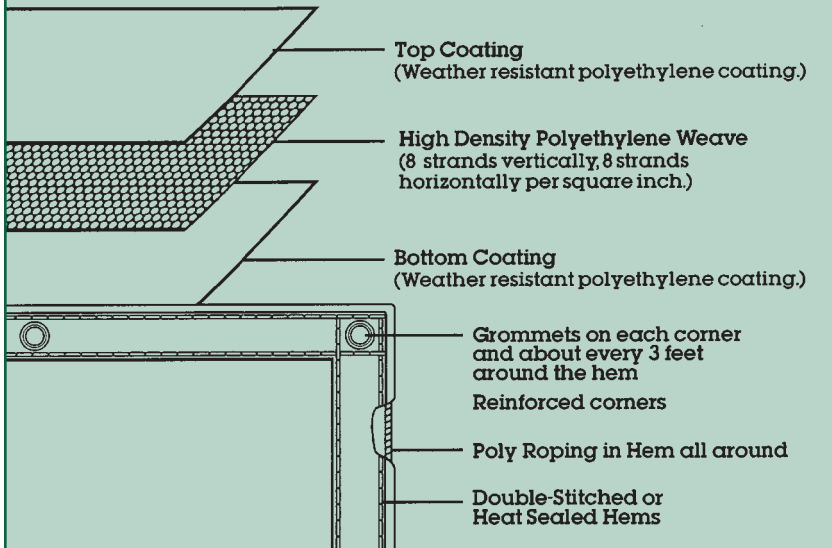

A WIDE RANGE OF USES:

- Roof Cover
- Windbreak
- Machinery Cover
- Construction Cover
- Boat Cover
- Ground Cover
- Pallet Cover

CONSTRUCTION FEATURES:

- 2.75 ounce per square yard
- 8 x 8 sq. in. count
- Heat-sealed seams
- 3/16" boltroping in hem
- Aluminum rustproof grommets about every three feet around hem
- 5-6 mil thickness
- UPC coded
- Blue both sides

| PART # | DESCRIPTION | QUANTITY |
|--------------|----------------------------|----------|
| PB006x008-30 | Blue Poly Tarp 6' x 8' | 30/pk |
| PB008x010-20 | Blue Poly Tarp 8' x 10' | 20/pk |
| PB010x012-15 | Blue Poly Tarp 10' x 12' | 15/pk |
| PB010x018-10 | Blue Poly Tarp 10' x 18' | 10/pk |
| PB010x020-8 | Blue Poly Tarp 10' x 20' | 8/pk |
| PB012x016-8 | Blue Poly Tarp 12' x 16' | 8/pk |
| PB012x020-7 | Blue Poly Tarp 12' x 20' | 7/pk |
| PB012x025-5 | Blue Poly Tarp 12' x 25' | 5/pk |
| PB016x020-5 | Blue Poly Tarp 16' x 20' | 5/pk |
| PB018x024-4 | Blue Poly Tarp 18' x 24' | 4/pk |
| PB020x025-3 | Blue Poly Tarp 20' x 25' | 3/pk |
| PB020x030-2 | Blue Poly Tarp 20' x 30' | 2/pk |
| PB020x040-2 | Blue Poly Tarp 20' x 40' | 2/pk |
| PB025x040-1 | Blue Poly Tarp 25' x 40' | 1/pk |
| PB030x040-1 | Blue Poly Tarp 30' x 40' | 1/pk |
| PB030x060-1 | Blue Poly Tarp 30' x 60' | 1/pk |
| PB040x040-1 | Blue Poly Tarp 40' x 40' | 1/pk |
| PB040x060-1 | Blue Poly Tarp 40' x 60' | 1/pk |
| PB050x050-1 | Blue Poly Tarp 50' x 50' | 1/pk |
| PB050x100-1 | Blue Poly Tarp 50' x 100' | 1/pk |
| PB060x060-1 | Blue Poly Tarp 60' x 60' | 1/pk |
| PB100x100-1 | Blue Poly Tarp 100' x 100' | 1/pk |

Sold only in case quantities

SUNSHIELD TARPS

SUNSHIELD

SILVER/BLACK TARPS

SILVER: Reflects Sunlight / **BLACK:** Blocks Sunlight

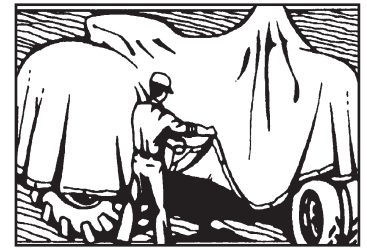

Tractor Covers



Lawn and Garden Covers



Firewood Covers

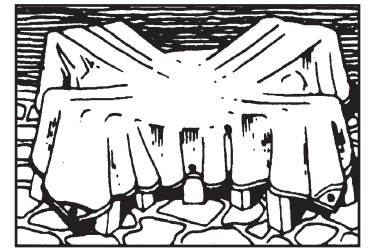

Patio Furniture Covers



Windbreaks

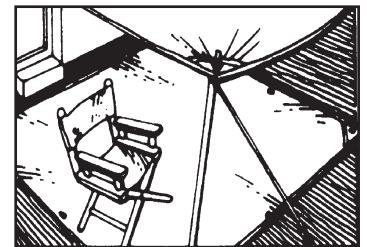

Ground Covers

PART #

DESCRIPTION

| | | |
|--------------|----------------------|-------|
| PS006x008-30 | Sunshield 6' x 8' | 30/pk |
| PS008x010-18 | Sunshield 8' x 10' | 18/pk |
| PS010x012-10 | Sunshield 10' x 12' | 10/pk |
| PS012x012-10 | Sunshield 12' x 12' | 10/pk |
| PS012x016-8 | Sunshield 12' x 16' | 8/pk |
| PS012x020-6 | Sunshield 12' x 20' | 6/pk |
| PS012x025-5 | Sunshield 12' x 25' | 5/pk |
| PS012x030-4 | Sunshield 12' x 30' | 4/pk |
| PS016x020-4 | Sunshield 16' x 20' | 4/pk |
| PS020x020-3 | Sunshield 20' x 20' | 3/pk |
| PS020x030-2 | Sunshield 20' x 30' | 2/pk |
| PS020x040-2 | Sunshield 20' x 40' | 2/pk |
| PS030x040-1 | Sunshield 30' x 40' | 1/pk |
| PS030x050-1 | Sunshield 30' x 50' | 1/pk |
| PS030x060-1 | Sunshield 30' x 60' | 1/pk |
| PS040x040-1 | Sunshield 40' x 40' | 1/pk |
| PS040x060-1 | Sunshield 40' x 60' | 1/pk |
| PS050x100-1 | Sunshield 50' x 100' | 1/pk |
| PS060x060-1 | Sunshield 60' x 60' | 1/pk |

Sold only in case quantities

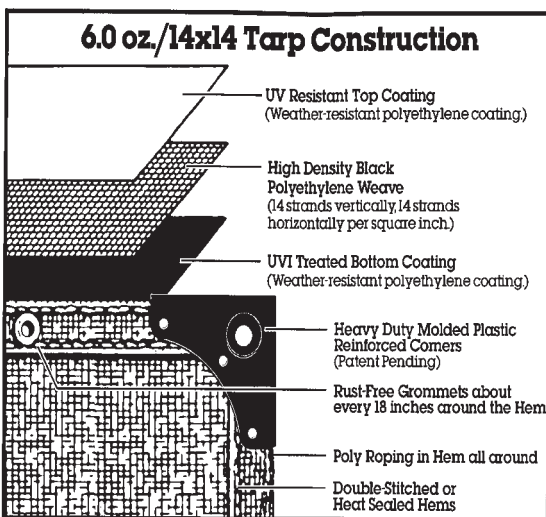

– MAXIMUM OUTDOOR PROTECTION –

Sunshield Silver/Black Tarps are very rugged and designed for use under continuous outdoor exposure. Sunshield is made with black high density woven fabric along with UVI treated coatings on both sides to provide extended life in the sunlight. In addition, using Sunshield with the reflective silver side up will divert both heat and ultraviolet light, while using the black side up will absorb heat and divert ultraviolet light. Both sides are heat and cold resistant. Sunshield is also an excellent sunblock fabric. The tarps include patent-pending molded reinforced corners, rustproof grommets every two feet and bolt rope hems to provide dependable tiedown points. Sunshield tarps are packaged in a heavy and high clarity PVC plastic bag with an insert label which includes UPC bar codes.

– CONSTRUCTION FEATURES –

- 6 oz per square yard
- 14 x 14 count per sq. in.
- High density black woven fabric (UVI treated) one side
- Heat sealed seams
- 3/16" bolt roping in hem
- Heavy-duty plastic reinforced corners
- Rust-free grommets every two feet
- Double stitched or heat welded hems
- 11-12 mil thickness
- UPC coded